



## Electronic Pressure Transmitter HDA 4400 with Approvals for Shipping

### Description:

This pressure transmitter has been specially developed for shipbuilding applications and is based on the HDA 4000 series. With its stainless steel measurement cell and thin-film strain gauge, the HDA 4400 is designed to measure relative pressures in the high pressure range. The evaluation electronics converts the measured pressure into a proportional analog signal of 4 .. 20 mA.

The electronic module is completely potted to protect it against humidity, vibrations and shock, and is enclosed in a solid stainless steel housing.

For use in the shipping industry, these pressure transmitters have been approved by the following organizations.

### Approvals:

- American Bureau of Shipping



- Lloyds Register of Shipping



- Det Norske Veritas



- Germanischer Lloyd



- Bureau Veritas



Other approvals on request

### Technical data:

#### Input data

Measuring ranges	150, 500, 750, 1000, 1500, 3000, 5000, 6000, 9000 psi
Overload pressures	290, 1160, 1740, 2900, 2900, 7250, 11600, 11600, 14500 psi
Burst pressures	1450, 2900, 4350, 7250, 7250, 14500, 29000, 29000, 29000 psi
Mechanical connection	9/16-18 UNF 2A (SAE 6 male)
Torque value	15lb-ft(20Nm)
Parts in contact with medium	Mech. connector: Stainless steel Seal: FPM

#### Output data

Output signal, permitted load resistance	4 .. 20 mA, 2 conductor $R_{Lmax} = (U_B - 10 V) / 20 \text{ mA} [k\Omega]$
Accuracy to DIN 16086, Max. setting	$\leq \pm 0.5 \% \text{ FS typ.}$ $\leq \pm 1 \% \text{ FS max.}$
Accuracy at min. setting (B.F.S.L.)	$\leq \pm 0.25 \% \text{ FS typ.}$ $\leq \pm 0.5 \% \text{ FS max.}$
Temperature compensation Zero point	$\leq \pm 0.0085\% \text{ FS} / ^\circ\text{F typ}$ $\leq \pm 0.014\% \text{ FS} / ^\circ\text{F max.}$
Temperature compensation Range	$\leq \pm 0.0085\% \text{ FS} / ^\circ\text{F typ.}$ $\leq \pm 0.014\% \text{ FS} / ^\circ\text{F max.}$
Non-linearity at max. setting to DIN 16086	$\leq \pm 0.3 \% \text{ FS max.}$
Hysteresis	$\leq \pm 0.4 \% \text{ FS max.}$
Repeatability	$\leq \pm 0.1 \% \text{ FS}$
Rise time	$\leq 1 \text{ ms}$
Long-term drift	$\leq \pm 0.3 \% \text{ FS typ.} / \text{ year}$

#### Environmental conditions

Compensated temperature range	-13..+185 °F
Operating temperature range <sup>1)</sup>	-40..+185 °F / -13..+185 °F
Storage temperature range	-40..+212 °F
Fluid temperature range <sup>1)</sup>	-40..+212 °F / -13..+212 °F
CE mark	EN 61000-6-1 / 2 / 3 / 4
Vibration resistance to DIN EN 60068-2-6 at 10 .. 500 Hz	$\leq 20 \text{ g}$
Protection class to IEC 60529	IP 65 (for male EN175301-803 (DIN 43650)) IP 67 (for M12x1 male when an IP 67 connector is used)

#### Other data

Supply voltage	10 .. 32 V DC
Residual ripple of supply voltage	$\leq 5 \%$
Life expectancy	> 10 million cycles 0 .. 100 % FS
Weight	~ 150 g

Note: Reverse polarity protection of the supply voltage, excess voltage, override and short circuit protection are provided.

FS (Full Scale) = relative to complete measuring range

B.F.S.L. = Best Fit Straight Line

<sup>1)</sup> -13 °F with FPM seal, -40 °F on request

## Model code:

HDA 4 4 X X - A - XXXX - S00 (PSI)

### Mechanical connection

7 = 9/16-18 UNF 2A (SAE 6 male)

### Electrical connection

5 = Male, 3 pole + PE, EN175301-803 (DIN 43650) (connector supplied)

6 = Male M12x1, 4 pole (connector not supplied)

### Signal

A = 4 .. 20 mA, 2 conductor

### Pressure ranges in psi

0150, 0500, 0750, 1000, 1500, 3000, 5000, 6000, 9000

### Modification number

S00 = With approvals for shipping

### Version

PSI = Pounds per square inch.

### Accessories:

Appropriate accessories, such as electrical connectors, can be found in the Accessories brochure.

## Pin connections:

EN175301-803 (DIN 43650)

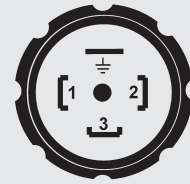

Pin HDA 44X5-A

1 Signal+

2 Signal-

3 n.c.

⊥ Housing

M12x1

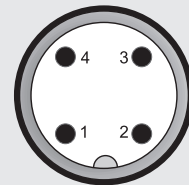

Pin HDA 44X6-A

1 Signal+

2 n.c.

3 Signal-

4 n.c.

## Dimensions:

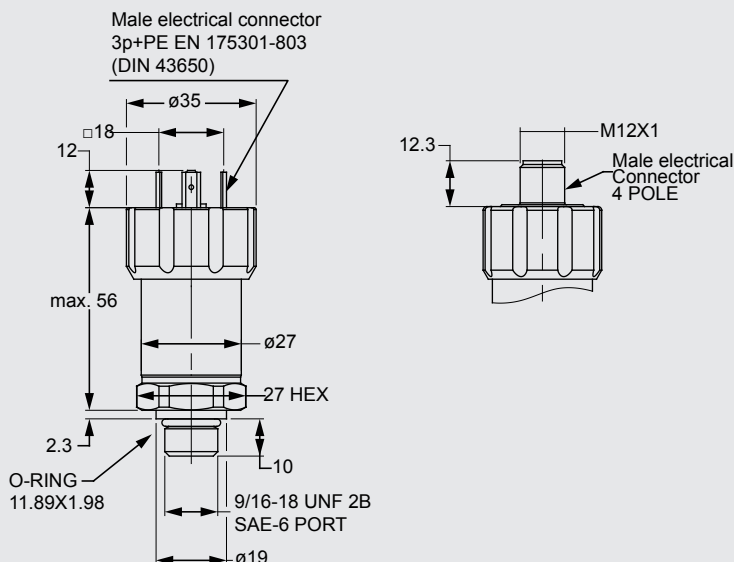
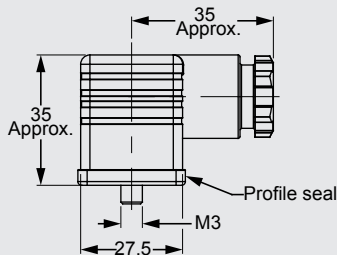

## Note:

The information in this brochure relates to the operating conditions and applications described.

For applications or operating conditions not described, please contact the relevant technical department.

Subject to technical modifications.

For European mechanical connection and bar ranges see European Catalog

## HYDAC ELECTRONICS

90 Southland Dr. Bethlehem, PA 18107

Telephone: 610.266.0100

E-mail: [electronics@hydacusa.com](mailto:electronics@hydacusa.com)

Website: [www.hydac-na.com](http://www.hydac-na.com)